

GG-HT

Straight Fluted Taps for Cast Irons Specification



M26~

Recommended Tapping Speeds depending on Materials

Grey cast iron
ISO K1
5~10
(m/min)

For icon explanation, refer to P.50

| Overall length | Thread length | Thread+Neck length | Shank length | Shank dia. | Size of square | Length of square |
|----------------|---------------|--------------------|----------------|----------------|----------------|------------------|
| L | ℓ | ℓ _n | ℓ _s | D _s | K | ℓ _k |



■ Suitable for hard and abrasive materials such as cast irons. Considering comparatively quick wear, GG-HT is properly oversized.

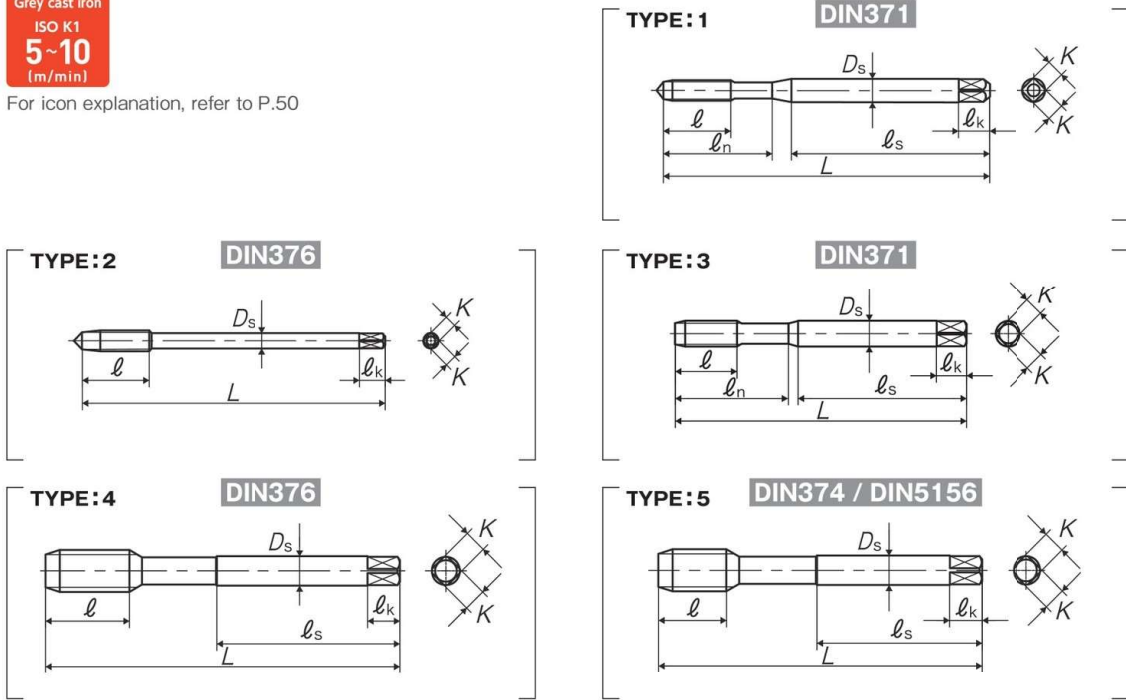

Segment : 1B

| Size | Class | Code | Chamfer | L (mm) | ℓ (mm) | ℓ _n (mm) | ℓ _s (mm) | D _s (mm) | K (mm) | ℓ _k (mm) | No. of flutes | Type | Stock |
|--------------------|-------|-------------|---------|--------|--------|---------------------|---------------------|---------------------|--------|---------------------|---------------|------|-------|
| For Metric Threads | | | | | | | | | | | | | |
| M3 × 0.5 | ISO2X | TD3.0GBAENC | 2.5P | 56 | 9 | 18 | 34 | 3.5 | 2.7 | 6 | 3 | 1 | ● |
| M4 × 0.7 | ISO2X | TD4.0IBAENC | 2.5P | 63 | 13 | 21 | 38 | 4.5 | 3.4 | 6 | 4 | 1 | ● |
| M5 × 0.8 | ISO2X | TD5.0KBAENC | 2.5P | 70 | 14 | 25 | 39 | 6 | 4.9 | 8 | 4 | 1 | ● |
| | | TG5.0KBAENC | 2.5P | 70 | 14 | - | - | 3.5 | 2.7 | 6 | 4 | 2 | ● |
| M6 × 1 | ISO2X | TD6.0MBAENC | 2.5P | 80 | 15 | 30 | 45 | 6 | 4.9 | 8 | 4 | 1 | ● |
| | | TG6.0MBAENC | 2.5P | 80 | 15 | - | - | 4.5 | 3.4 | 6 | 4 | 2 | ● |
| M8 × 1.25 | ISO2X | TD8.0NBAENC | 2.5P | 90 | 19 | 35 | 47 | 8 | 6.2 | 9 | 4 | 3 | ● |
| | | TG8.0NBAENC | 2.5P | 90 | 19 | - | 46 | 6 | 4.9 | 8 | 4 | 4 | ● |
| M8 × 1 | ISO2X | TM8.0MBAENC | 2.5P | 90 | 19 | - | 46 | 6 | 4.9 | 8 | 4 | 5 | ● |
| M10 × 1.5 | ISO2X | TD0100BAENC | 2.5P | 100 | 23 | 39 | 52 | 10 | 8 | 11 | 4 | 3 | ● |
| | | TG0100BAENC | 2.5P | 100 | 23 | - | 51 | 7 | 5.5 | 8 | 4 | 4 | ● |
| M10 × 1.25 | ISO2X | TM010NBAENC | 2.5P | 100 | 23 | - | 51 | 7 | 5.5 | 8 | 4 | 5 | ● |
| M10 × 1 | ISO2X | TM010MBAENC | 2.5P | 90 | 19 | - | 46 | 7 | 5.5 | 8 | 4 | 5 | ● |
| M12 × 1.75 | ISO2X | TG012PBAENC | 2.5P | 110 | 26 | - | 56 | 9 | 7 | 10 | 4 | 4 | ● |
| M12 × 1.5 | ISO2X | TM0120BAENC | 2.5P | 100 | 21 | - | 51 | 9 | 7 | 10 | 4 | 5 | ● |
| M12 × 1.25 | ISO2X | TM012NBAENC | 2.5P | 100 | 21 | - | 51 | 9 | 7 | 10 | 4 | 5 | ● |

Think threads with
YAMAWA

DIN
HT-14

147

Spiral Fluted Taps (for blind hole)
Spiral Fluted Taps (for through hole)
Spiral Pointed Taps (for through hole)
Straight Fluted Taps
Cemented Carbide Taps
Roll Taps
Special Thread Taps
Simple Inspection Tools
Pipe Taps
Thread Mills
Dies
Center Drills
Centering Tools

Straight Fluted Tap Series

GG-HT Straight Fluted Taps for Cast Irons

| Size | Class | Code | Chamfer | L (mm) | ℓ (mm) | ℓn (mm) | ℓs (mm) | Ds (mm) | K (mm) | ℓk (mm) | No. of flutes | Type | Stock |
|------------------|-------|-------------|---------|-----------|-----------|------------|------------|------------|-----------|------------|------------------|------|-------|
| M12 × 1 | ISO2X | TM012MBAENC | 2.5P | 100 | 21 | - | 51 | 9 | 7 | 10 | 4 | 5 | ● |
| M14 × 2 | ISO2X | TG014QBAENC | 2.5P | 110 | 26 | - | 56 | 11 | 9 | 12 | 4 | 4 | ● |
| M14 × 1.5 | ISO2X | TM0140BAENC | 2.5P | 100 | 21 | - | 51 | 11 | 9 | 12 | 4 | 5 | ● |
| M16 × 2 | ISO2X | TG016QBAENC | 2.5P | 110 | 26 | - | 56 | 12 | 9 | 12 | 4 | 4 | ● |
| M16 × 1.5 | ISO2X | TM0160BAENC | 2.5P | 100 | 21 | - | 51 | 12 | 9 | 12 | 4 | 5 | ● |
| M18 × 2.5 | ISO2X | TG018RBAENC | 2.5P | 125 | 33 | - | 64 | 14 | 11 | 14 | 4 | 4 | ● |
| M18 × 1.5 | ISO2X | TM0180BAENC | 2.5P | 110 | 24 | - | 56 | 14 | 11 | 14 | 4 | 5 | ● |
| M20 × 2.5 | ISO2X | TG020RBAENC | 2.5P | 140 | 33 | - | 71 | 16 | 12 | 15 | 4 | 4 | ● |
| M20 × 1.5 | ISO2X | TM0200BAENC | 2.5P | 125 | 24 | - | 64 | 16 | 12 | 15 | 4 | 5 | ● |
| M22 × 2.5 | ISO2X | TG022RBAENC | 2.5P | 140 | 33 | - | 71 | 18 | 14.5 | 17 | 4 | 4 | ● |
| M22 × 1.5 | ISO2X | TM0220BAENC | 2.5P | 125 | 24 | - | 64 | 18 | 14.5 | 17 | 4 | 5 | ● |
| M24 × 3 | ISO2X | TG024SBAENC | 2.5P | 160 | 37 | - | 82 | 18 | 14.5 | 17 | 4 | 4 | ● |
| M24 × 1.5 | ISO2X | TM0240BAENC | 2.5P | 140 | 27 | - | 71 | 18 | 14.5 | 17 | 4 | 5 | ● |
| Size | Class | Code | Chamfer | L (mm) | ℓ (mm) | ℓn (mm) | ℓs (mm) | Ds (mm) | K (mm) | ℓk (mm) | No. of flutes | Type | Stock |
| For G Threads | | | | | | | | | | | | | |
| G1/8-28 | - | TVG0020AENC | 2.5P | 90 | 19 | - | 46 | 7 | 5.5 | 8 | 4 | 5 | ● |
| G1/4-19 | - | TVG0040AENC | 2.5P | 100 | 21 | - | 51 | 11 | 9 | 12 | 4 | 5 | ● |
| G3/8-19 | - | TVG0060AENC | 2.5P | 100 | 21 | - | 51 | 12 | 9 | 12 | 4 | 5 | ● |
| G1/2-14 | - | TVG0080AENC | 2.5P | 125 | 24 | - | 64 | 16 | 12 | 15 | 4 | 5 | ● |
| G3/4-14 | - | TVG0120AENC | 2.5P | 140 | 27 | - | 71 | 20 | 16 | 19 | 4 | 5 | ● |
| G1-11 | - | TVG0160AENC | 2.5P | 160 | 29 | - | 82 | 25 | 20 | 23 | 4 | 5 | ● |

Spiral Fluted Taps
(for blind hole)

Spiral Fluted Taps
(for through hole)

Spiral Pointed Taps
(for through hole)

Straight
Fluted Taps

Cemented
Carbide Taps

Roll Taps

Special Thread Taps
Simple Inspection Tools

Pipe Taps

Thread Mills

Dies

Center Drills

Centering Tools

DIN
HT-15

148

Think threads with
YAMAWA